

Spiral Sash Balance Installation

Telephone 01935 826960
 Facsimile 01935 829215
 Website www.balanceuk.com
 Information Sheet No. 6

Type 'F', 'K' and 'M' balances

Read instructions fully before installing balances.

It is recommended that before balances are installed the sashes are glazed and in the case of timber windows all painting is completed ensuring that both sashes slide freely in the frame. While sketches show timber windows throughout, fitting instructions apply to all types.



Preparation of Windows

1 Grooving details
 Provision must be made to house each balance in a groove or channel which can be either in frame jamb (Fig. 1), or in the sash stile (Fig. 2), and must be of minimum dimensions shown on table below. The groove must be run the full length of the sash run.

Grooving dimensions

Balance Type	D	F	K	M
Dimension X (mm)	16	17	21.5	26
Dimension Y (mm)	17	17	21.5	27

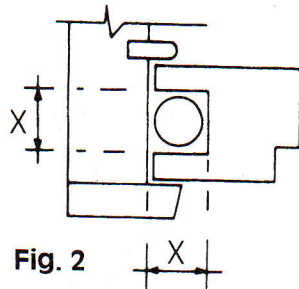
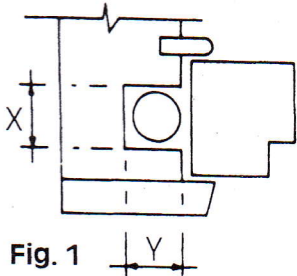

Bottoms of sashes should be prepared to suit balance foot attachment to be used. Cut-outs to be of sufficient depth to receive attachments and screw heads.

Fig. 3 Bottom rail preparation for standard 'F' balance foot.

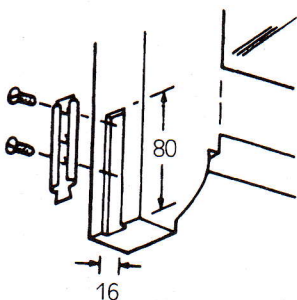
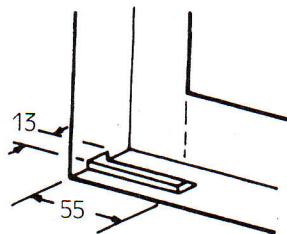

Fig. 4 Stile preparation for channel fitting for standard 'F' balance foot. (Fix channel prior to fitting sash into frame)

Fig. 5 Bottom rail preparation for standard 'K' and 'M' balance foot. (grooved stile shown).

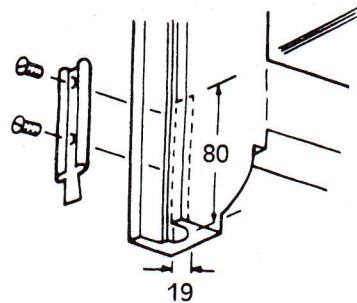
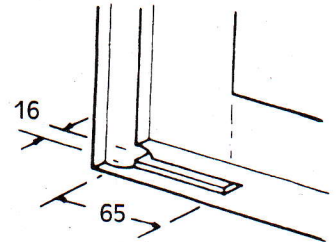
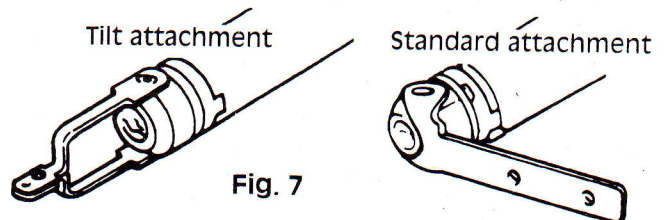

Fig. 6 Grooved stile preparation for channel fitting for standard 'K' and 'M' balance foot. (fix channel prior to fitting sash into frame).

Checking balances

2 It is important that the balances used are suitable for the weight of the sash. 'F', 'K' and 'M' balances are made to suit the weight of the sash for which they are ordered. The relevant weight in lbs is printed on the tube or stamped on the foot attachment. Check that the finished sash weight is within 1lb (0.5kg) of the figure. (see Fig. 7)



'F' balances are made to suit sash weights from 6.8Kg (15lbs) to 24.9Kg (55lbs) and have a 15mm (5/8") tube diameter
 'K' balances are made to suit sash weights from 9.0Kg (20lbs) to 37.6Kg (83lbs) and have a 19mm (3/4") tube diameter
 'M' balances are purpose made to suit sash weights from 6.8Kg (15lbs) to 45.4Kg (100lbs) and have a 22.5mm (7/8") tube diameter

Installing Balances

3

Note that the shorter pair of balances is normally for the top sash, given sashes of equal height.

With the sashes lowered, insert the appropriate pair of balances into the grooves (Fig. 8). In the case of unequal size sashes it is possible to slightly bow the balance for insertion into the groove of the larger sash. In some cases, larger sashes may have to be removed.

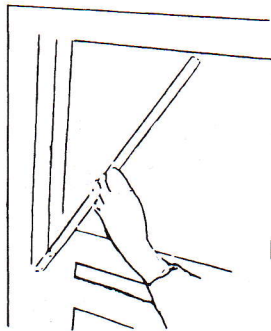

Fig. 8

Fit the top of the balances to the frame jamb at the centre of the groove tight up against the frame head, with the flat of the foot attachment against the jamb. Fix using woodscrews provided (Fig. 9).

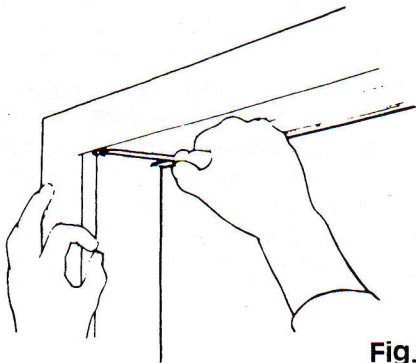

Fig. 9

To attach balances to sashes, firstly raise the sashes as high as possible and prop in position. The foot attachment at the bottom of each balance should now be visible.

Now fold the foot attachment under the bottom rail of the sash.

Using the woodscrews provided, fix the foot attachment to the underside of the bottom rail, ensuring that the balance is kept tight to the sash. (Fig. 10).

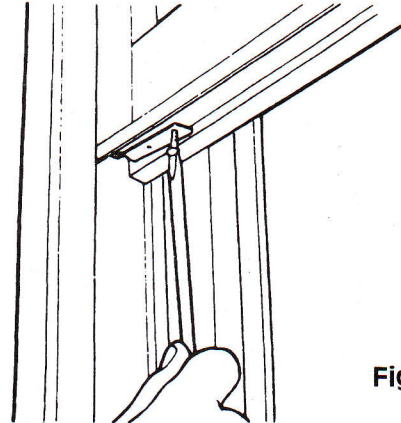

Fig.10

Alternative Method

For unequal sashes, very heavy sashes and/or sashes with horns

Before inserting balances into groove you can insert an F and K installation tool (FKINSTOOL - available from Balance UK) into the brass thread at the bottom of the balance.

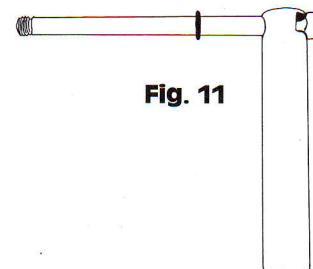

Fig. 11

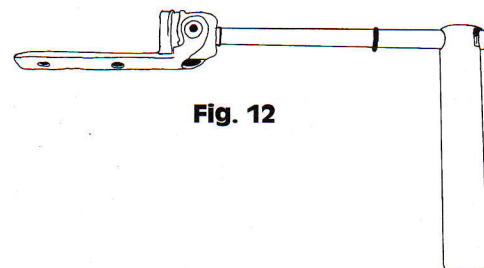

Fig. 12

Proceed as previously described, using the tool, pull the foot attachment downwards and across under the bottom rail of the sash. Fix using woodscrews provided before fully tightening screws, carefully remove the FKINSTOOL.

For sashes with horns, using the standard horn channel attachments (pre-fixed in Section 1, Fig. 4 and Fig. 5) use the tool to pull the balance foot down so that it can be located into the bottom of the channel and then carefully released. Carefully remove the FKINSTOOL.

Fix travel stops

- 4** Fix travel stops provided, the shorter one at the top of the bottom sash run, see Fig. 13.

In the case of non-standard applications special stops may be required. In such cases suitable longer timber stops should be substituted for the standard metal type supplied. These should be long enough to prevent the balance from being extended by more than twice its tube length minus 2 inches.

IMPORTANT

FAILURE TO FIT TRAVEL STOPS MAY RESULT IN BALANCE FAILURE

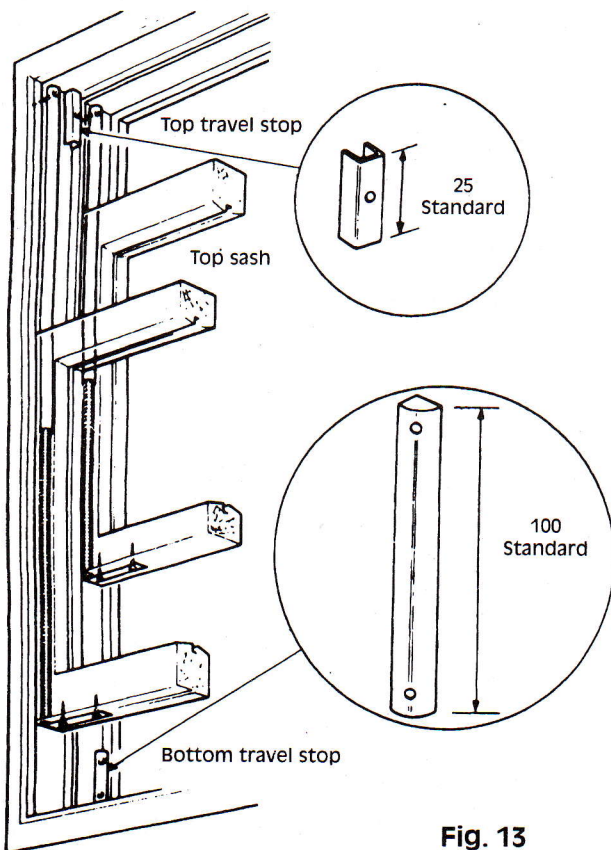

Fig. 13

Maintenance

Depending upon location and frequency of use, lubrication of the internal mechanism of the balance may be desirable after a length of time, the period of which will vary according to site circumstances. A few drops of light oil or spray such as WD40 applied via the top end of the balance tube will always improve the operating action of a balance after a long service.

Balancing sashes adjusting balances

- 5** Try the sashes up and down TO THE LIMIT OF THEIR TRAVEL. If there is a tendency for either sash to drop when in the up position, adjust the balances as follows:

A screwdriver can now be inserted in the slot in the ratchet fitting at the bottom of the balance (see Fig. 14). Adjust by turning the ratchet in an anti-clockwise direction as viewed from underside (see Fig. 14). Two 'clicks' of the ratchet equal one complete turn. Refer to adjustment chart overleaf for the number of turns to be added. Ensure that the same number of turns are applied to each balance pair. Do not over tension.

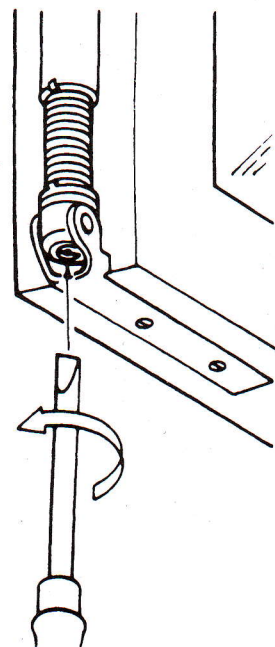

Fig.14

Important

- Don't** use balances on sashes beyond their respective weight.
- Don't** tension balances more than necessary.
- Don't** tension balances before glazing.
- Do** keep the foot attachment tight into the sash and make sure that the covers of the fitting do not rub the jamb when the sash is moved.
- Do** fit correct travel stops.

Adjustment Charts

'F' and 'K' balances are pre-tensioned and therefore should be correct weight for the sash provided the information supplied was correct.

The 'F' and 'K' balances should not need adjusting but if they do adjust according to section 5 of the 'installation instructions'.

For the 'M' balances please read the chart below with reference to section 5 of the 'installation instructions'

Denotes type of balance (e.g. FO, F1, K)

← **FO** **16** **045** →

Weight of sash in lbs.

↓
Tube length in inches (e.g. 16 inches)

Type 'M' Balances

Tube Length (Ins)	Kgs lbs	9 20	11.3 25	13.6 30	15.9 35	18.1 40	20.4 45	22 50	25 55	27.2 60	29.4 65	31.7 70	34 75	36.2 80	38.5 85	40.8 90	43.1 95	45.4 100
20		2	0.5	1	1	2	2	2	3	3	3	4	1	2	2	2	3	3
24		2	0.5	1	1	2	2	2	3	3	3	4	2	2	2	3	3	4
28		2	1	1	2	2	2	2	3	3	4	5	2	2	3	4	4	4
32		2	1	2	2	2	3	3	4	4	5	6	2	3	3	4	4	5
36		3	2	2	2	3	3	3	4	4	6	7	3	3	4	5	5	5
40		3	2	2	2	3	4	4	5	5	7	8	3	4	4	5	5	6
44		4	2	2	3	3	4	4	5	5	7	8	3	4	4	5	6	6
48		4	2	3	3	4	5	5	6	6	8	9	4	5	5	6	6	7
52		5	3	3	3	4	5	5	6	6	8	9	4	5	5	6	7	7
56		5	3	3	4	4	5	5	6	6	9	9	4	5	5	7	7	8
60		6	3	3	4	5	6	6	7	7	9	10	5	6	6	7	8	8
64		6	4	4	4	5	6	6	7	7	9	10	5	6	6	8	8	9
68		7	4	4	5	6	6	6	8	8	10	11	6	6	7	8	9	9
72		7	4	4	5	6	7	7	8	9	10	11	6	7	7	8	9	10